

Waste/recycle sets



Waste/recycle sets

Premium TANDEM and TANDEMBOX solutions for waste/recycle cabinets

blum.com

Perfecting motion  **blum**[®]



SERVO-DRIVE
inside

BLUMOTION
inside

Waste/recycle solutions for every kitchen



Blum's new TANDEM and TANDEMBOX waste/recycle sets are the premium solutions for waste/recycle cabinets in the kitchen. They feature BLUMOTION soft closing and TANDEM smooth running action.

With the SERVO-DRIVE touch-to-open feature, drawers open automatically with just a touch of the drawer front or a light pull of the handle. Customers will be amazed by the quality and ease of use.

Other applications



Interior roll-out



Bottom mount

TANDEMBOX waste/recycle set with SERVO-DRIVE

Application



Description

- Pre-assembled bottom mount solution
- TANDEMBOX heavy duty full extension drawer system
- For 12", 15" and 18" minimum opening widths
- For face frame and panel applications
- Three-dimensional drawer front adjustment
- Maximum 6 (1/4") cabinet bottom recess
- TANDEM smooth running action
- 175 lb static, 150 lb dynamic load rating
- SERVO-DRIVE touch-to-open feature

Basic components

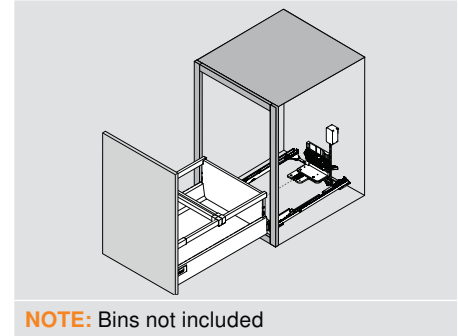

NOTE: Bins not included

Components

TANDEMBOX waste/recycle set

SERVO-DRIVE
inside

BLUMOTION
inside

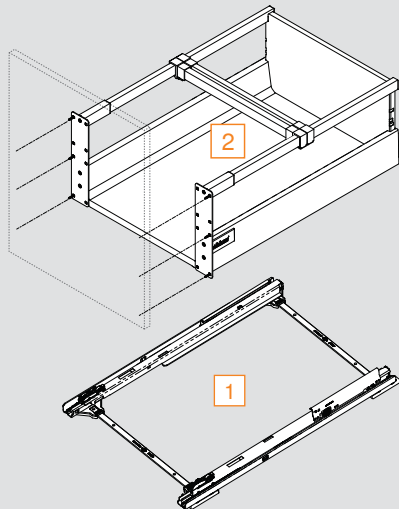

Set includes:

- 1 TANDEMBOX heavy duty runner set with pre-mounted #6 x 1" wood screws for installation (qty 8)
- 2 Pre-assembled silk white TANDEMBOX drawer
 - Installation template and instructions
 - #6 x 5/8" wood screws for attachment to drawer front (qty 10)
 - TANDEMBOX cover caps (qty 2)

TANDEMBOX waste/recycle set	Drawer length	Part no.
For 12" min. opening width	550 (21-5/8")	356M55B7SAB
For 15" min. opening width	550 (21-5/8")	356M55B7SAD
For 18" min. opening width	550 (21-5/8")	356M55B7SAF

SERVO-DRIVE waste/recycle set

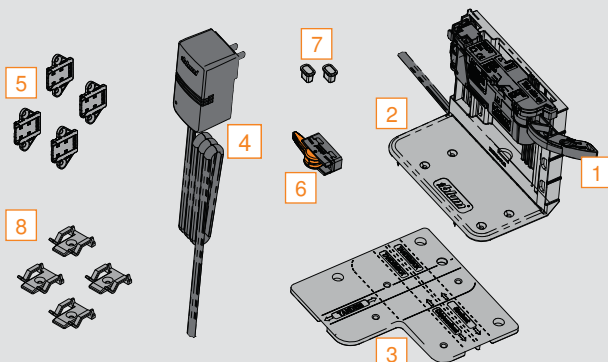

Set includes:

- 1 Drive unit (pre-attached)
- 2 Double bottom bracket with #6 x 1" wood screws (qty 2)
- 3 Adapter plate
- 4 110V plug-in power supply with six feet of universal cable
- 5 Screw-on distance bumpers (qty 4) with #6 x 5/8" wood screws for installation (qty 8)
- 6 INSERTA cable connector
- 7 Cable end protectors (qty 2)
- 8 Cable clips (qty 4)
- Installation template, instructions and user manual

SERVO-DRIVE waste/recycle set	Part no.
	Z10NA20UGUS

NOTE: Power supply will operate up to two drive units in a double bottom bracket application (second drive unit sold separately)

Specifications

SERVO-DRIVE
inside

BLUMOTION
inside

Drawer and cabinet specifications

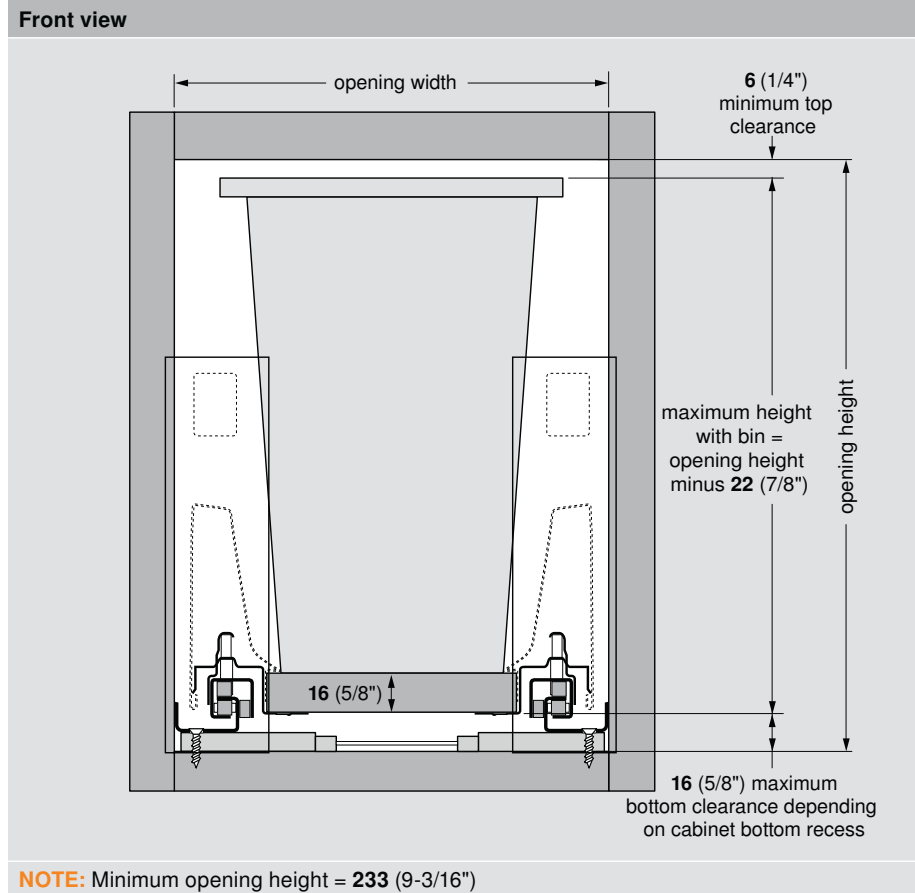

Waste/recycle set	356M55B7SAB	356M55B7SAD	356M55B7SAF
Z	146.5 (5-25/32")	184.5 (7-1/4")	222.5 (8-3/4")
Min. opening width	305 (12")	381 (15")	457 (18")

Set mounting specifications

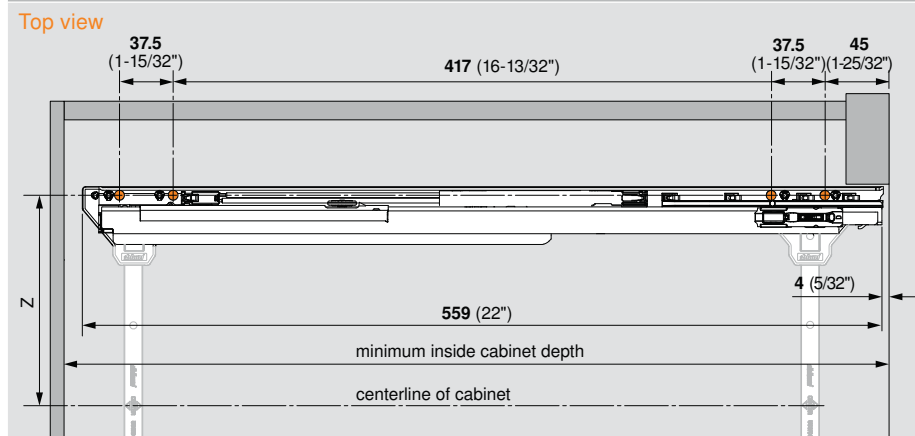

NOTE: Orange dots indicate pre-mounted screw locations. All four are required to meet specified load capacities.



Important

Bin width and height must be considered when designing your cabinet (see the diagram on the left).

Drawer front attachment

Typical panel

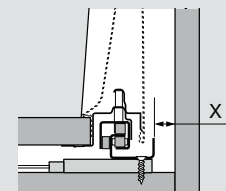

Typical face frame

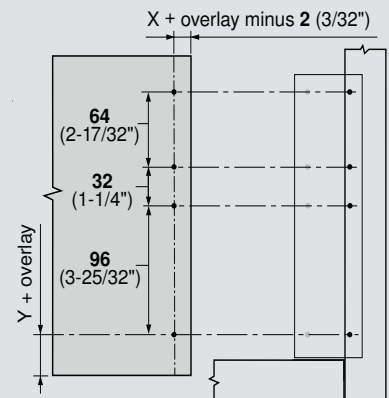
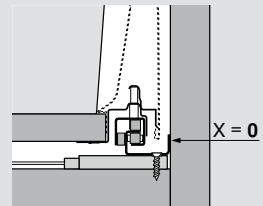

Cabinet bottom recess

	6 (1/4")	3 (1/8")	Flush
Y	16 (5/8")	19 (3/4")	22 (7/8")

Minimum inside cabinet depth

With SERVO-DRIVE	574 (22-19/32")
Without SERVO-DRIVE	569 (22-13/32")

TANDEM waste/recycle set with SERVO-DRIVE

Application



Description

- Pre-assembled bottom mount set
- TANDEM plus BLUMOTION heavy duty full extension concealed drawer runners
- For 12", 15" and 18" minimum opening widths
- For 16 (5/8") max. drawer side thickness
- For face frame and panel applications
- Tool-free height and tilt adjustment
- Maximum 6 (1/4") cabinet bottom recess
- 125 lb static, 110 lb dynamic load rating
- SERVO-DRIVE touch-to-open feature

Basic components

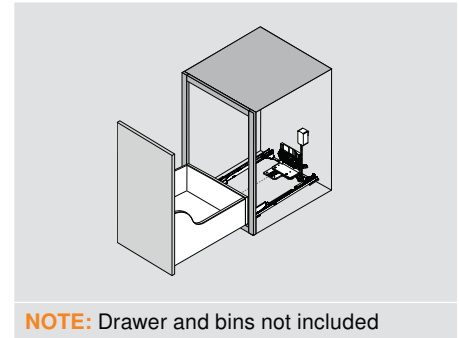

Components

TANDEM waste/recycle set

SERVO-DRIVE
inside

BLUMOTION
inside

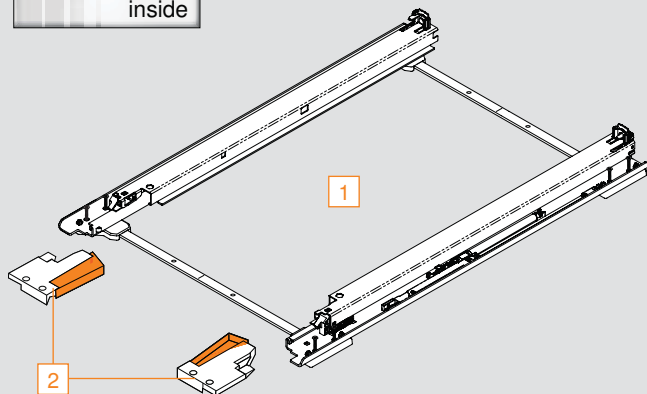

Set includes:

- 1 TANDEM plus BLUMOTION heavy duty runner set with pre-mounted #6 x 1" wood screws for installation (qty 8)
 - 2 Standard locking device (qty 2) with #6 x 1/2" truss head wood screws for installation (qty 4)
- Installation template and instructions

TANDEM waste/recycle set	Drawer length	Part no.
For 12" min. opening width	533 (21")	568R5337BB
For 15" min. opening width	533 (21")	568R5337BD
For 18" min. opening width	533 (21")	568R5337BF

SERVO-DRIVE waste/recycle set

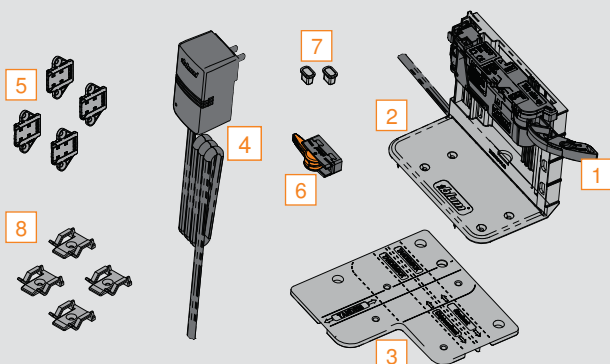

Set includes:

- 1 Drive unit (pre-attached)
 - 2 Double bottom bracket with #6 x 1" wood screws (qty 2)
 - 3 Adapter plate
 - 4 110V plug-in power supply with six feet of universal cable
 - 5 Screw-on distance bumpers (qty 4) with #6 x 5/8" wood screws for installation (qty 8)
 - 6 INSERTA cable connector
 - 7 Cable end protectors (qty 2)
 - 8 Cable clips (qty 4)
- Installation template, instructions and user manual

Part no.

SERVO-DRIVE waste/recycle set	Z10NA20UGUS
-------------------------------	-------------

NOTE: Power supply will operate up to two drive units in a double bottom bracket application (second drive unit sold separately)

Specifications

SERVO-DRIVE
inside

BLUMOTION
inside

Drawer and cabinet specifications

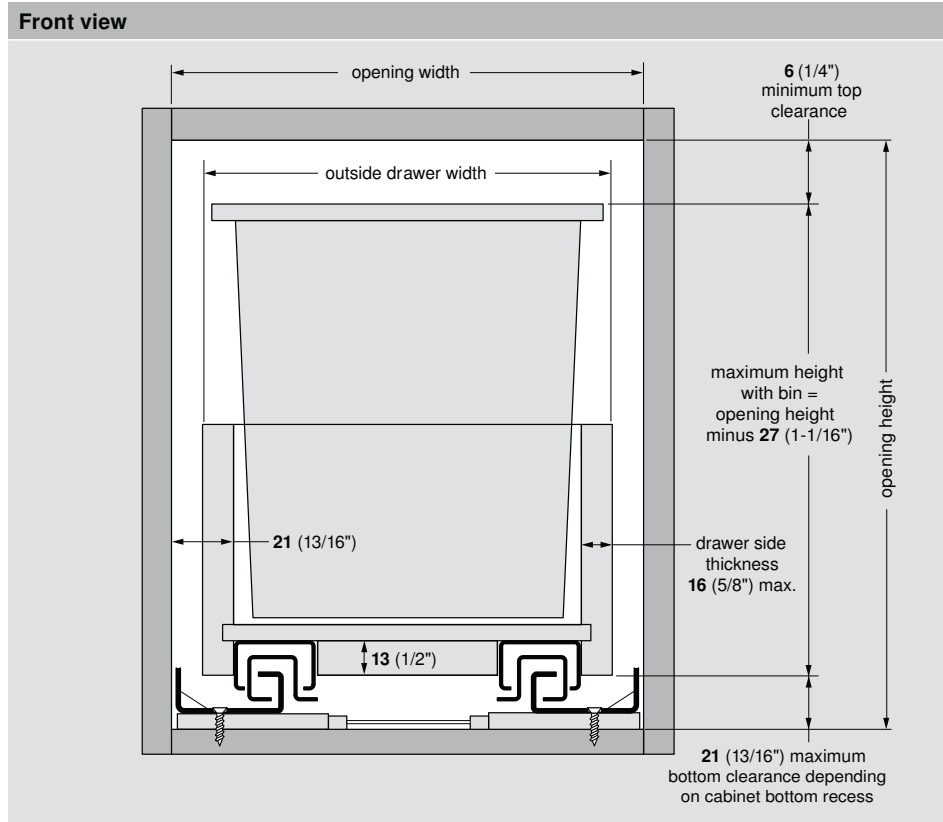

i Important

Bin width and height must be considered when designing your cabinet and drawer (see the diagram on the left).

Minimum inside cabinet depth

With SERVO-DRIVE	577 (22-23/32")
Without SERVO-DRIVE	556 (21-7/8")

Drawer back preparation

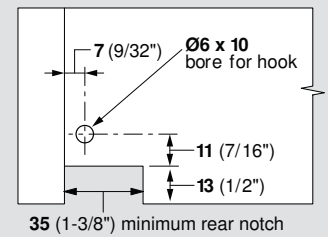

Waste/recycle set	opening width	Z	For drawer side thickness				
			16 (5/8")	15 (19/32")	14 (9/16")	13 (1/2")	12 (15/32")
568R5337BB	305 (12")	141.5 (5-9/16")	295 (11-5/8")	293 (11-17/32")	291 (11-15/32")	289 (11-3/8")	287 (11-5/16")
568R5337BD	381 (15")	179.5 (7-1/16")	371 (14-19/32")	369 (14-17/32")	367 (14-7/16")	365 (14-3/8")	363 (14-9/32")
568R5337BF	457 (18")	217.5 (8-9/16")	447 (17-19/32")	445 (17-17/32")	443 (17-7/16")	441 (17-3/8")	439 (17-9/32")

NOTE: Drawer length is 533 (21") for all sets

Outside drawer width

Set mounting specifications

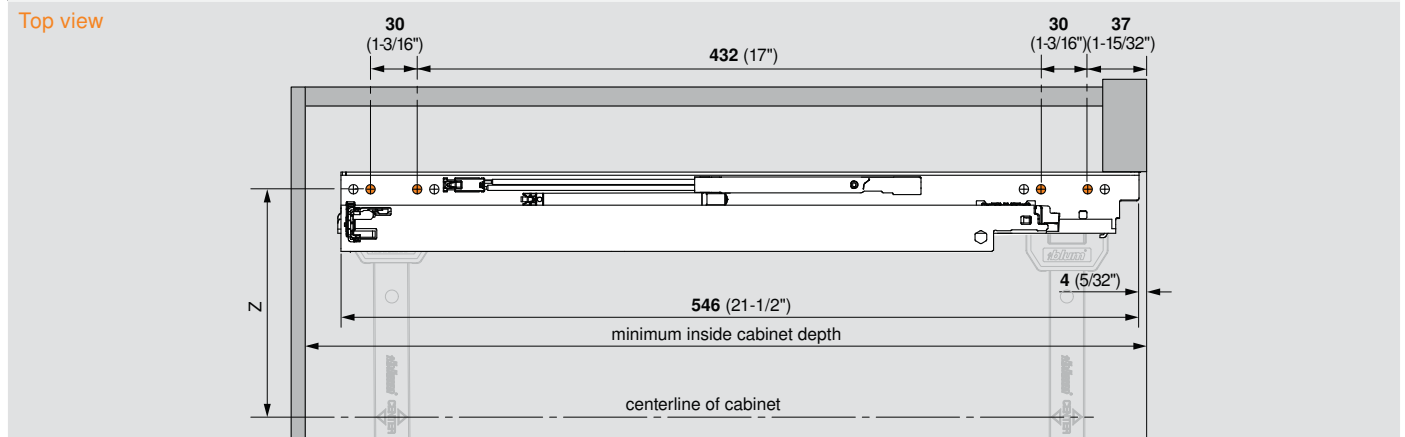

NOTE: Orange dots indicate pre-mounted screw locations. All four are required to meet specified load capacities.

TANDEM plus BLUMOTION 568R heavy duty bottom mount drawer runners

Application



Description

- Full extension bottom mount concealed drawer runners with BLUMOTION
- For **16** (5/8") max. drawer side thickness
- For face frame and panel applications
- Tool-free height and tilt adjustment
- Concealed roller carriages with permanently lubricated synthetic rollers create a smooth running action
- Locking devices enable easy drawer insertion and removal
- Force-guided right side and ± 1.5 (1/16") tolerance-compensating left side
- 125 lb static, 110 lb dynamic load capacity

Basic components

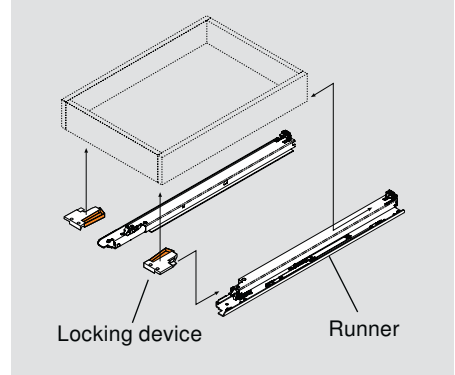

Applications

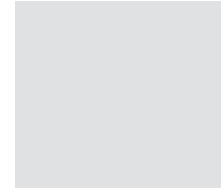
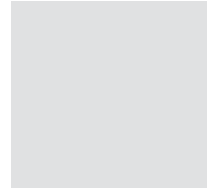
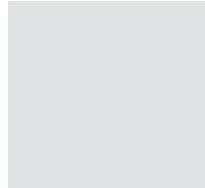

Components

TANDEM plus BLUMOTION bottom mount runner set

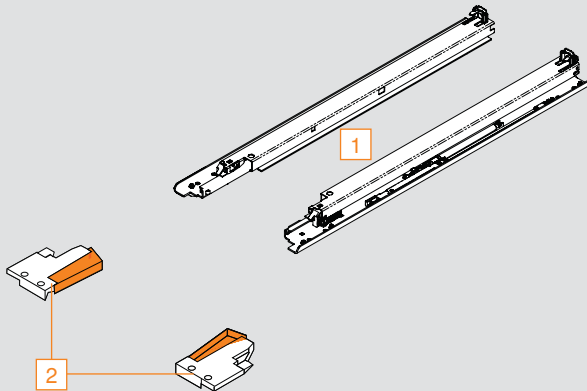

Set includes:

- 1 TANDEM plus BLUMOTION heavy duty runner set with #6 x 5/8" wood screws for installation (qty 10)
 - 2 Standard locking device (qty 2) with #6 x 1/2" truss head wood screws for installation (qty 4)
- Instructions

Overall cabinet depth	Drawer length	Extension loss	TANDEM plus BLUMOTION set
610 (24")	533 (21")	19 (3/4")	568R5330B

NOTE: These runners are for **16** (5/8") maximum drawer side thickness

Interior roll-outs and roll-out shelf applications

Interior roll-outs and roll-out shelf applications must be mounted to the bottom of the cabinet or to a fixed shelf/panel.

Rear mounting bracket for frame cabinets

Rear brackets and sockets cannot be used. Cabinet bottom must be flush with top surface of bottom rail.

Drawer and cabinet specifications

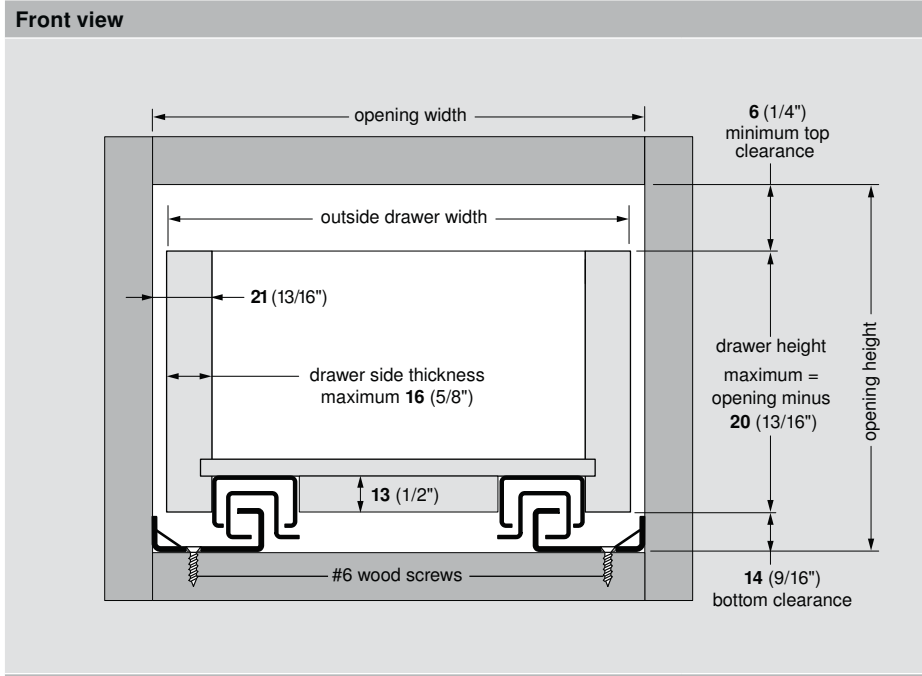

Calculating outside drawer width

For drawer side thickness	16 (5/8")	15 (19/32")	14 (9/16")	13 (1/2")	12 (15/32")
Deduct from inside cabinet width	10 (13/32")	12 (15/32")	14 (9/16")	16 (5/8")	18 (23/32")

Example: For 21" inside cabinet width and a 5/8" thick drawer, 21" minus 3/8" = 20-5/8" drawer width

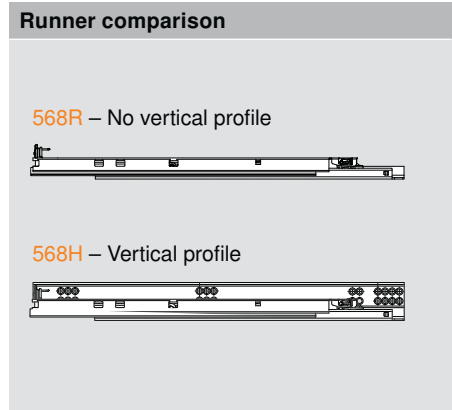
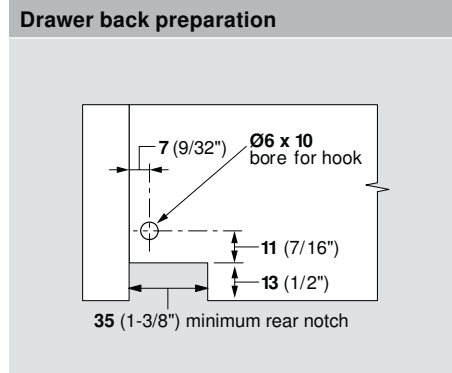

Profile mounting specifications

Top view

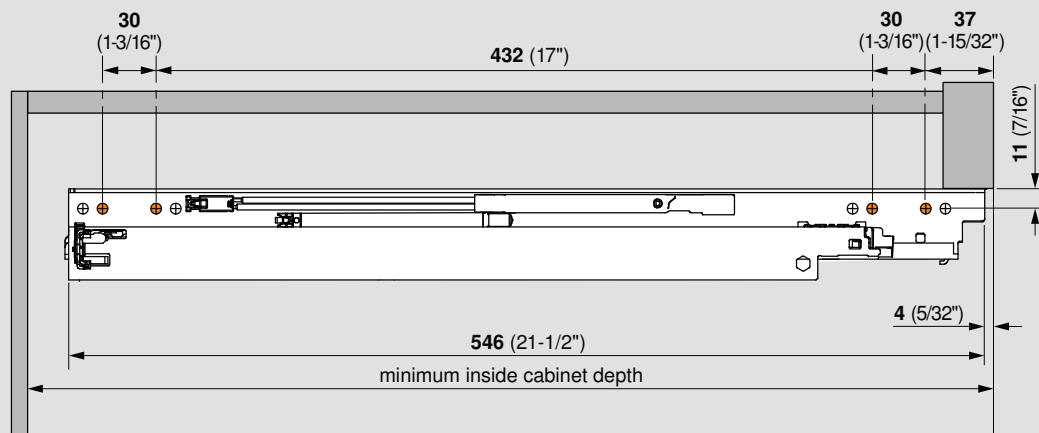

NOTE: Orange dots indicate screw locations required to meet specified load capacities (minimum 4 screws)

TANDEMBOX adjustments

Bin configurations

15" wide cabinet — one bin

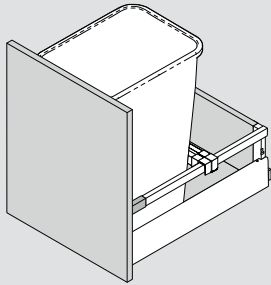

18" wide cabinet — two bins

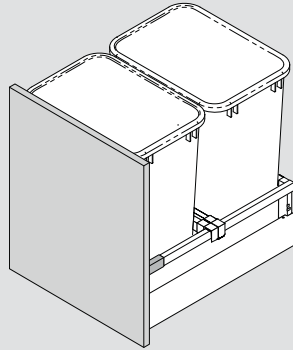

21" wide cabinet — two bins

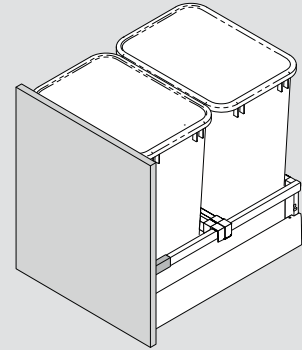

Accommodates a wide range of standard bin sizes.

Drawer adjustment

Height adjustment

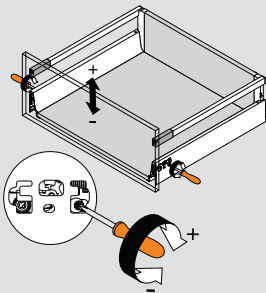

Use a Phillips screwdriver to adjust drawer front up or down as shown (+/- 2 mm). Repeat on left side if necessary.

Side adjustment

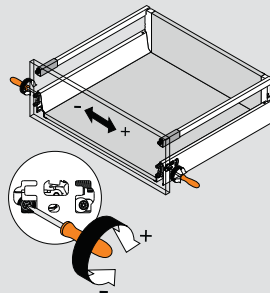

Use a Phillips screwdriver to adjust drawer front left or right (+/- 2 mm). Adjust left or right side equally by turning both toward or away from drawer front.

Tilt adjustment

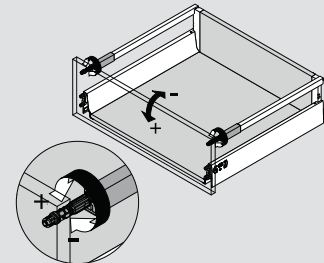

Slide gallery cover towards drawer back. Rotate orange adjustment piece as shown and slide cover back towards drawer front. Repeat on left side if necessary.

Drawer insertion and removal

Insertion

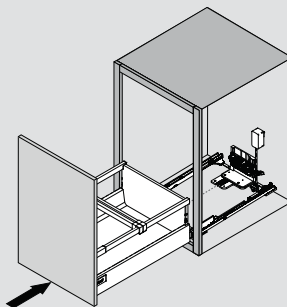
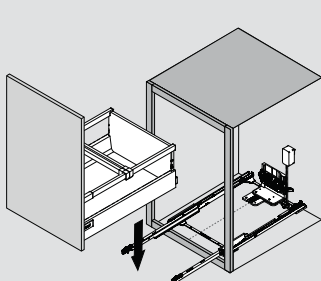

Removal

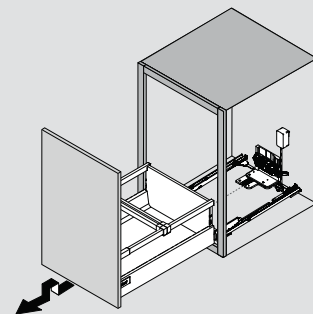

Cross rail adjustment

1 Slide to desired position

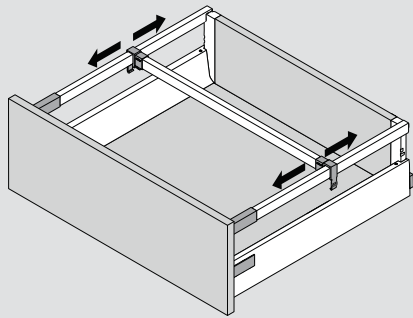

2 Lock cross rail into place

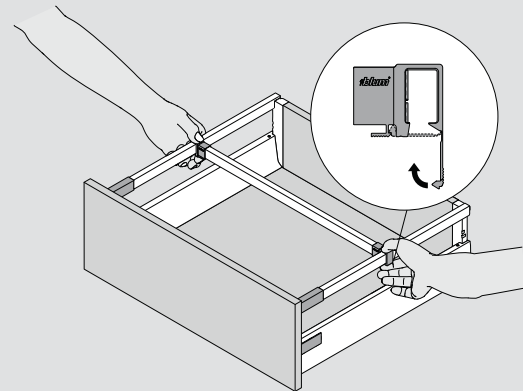

Cross rail removal

1 Unlock cross rail

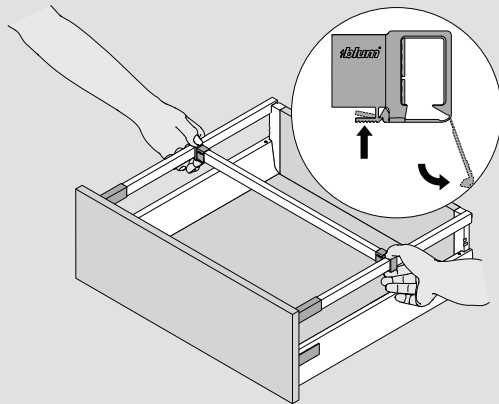

2 Lift cross rail to remove

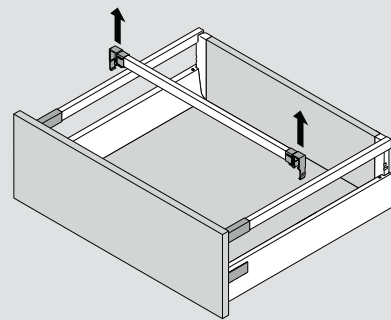

TANDEM adjustments

Bin configurations

15" wide cabinet — one bin

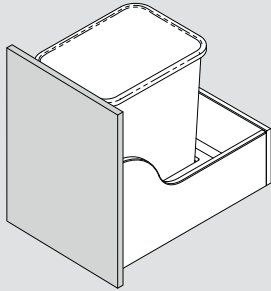

18" wide cabinet — two bins

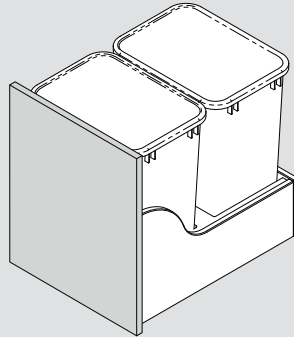

21" wide cabinet — two bins

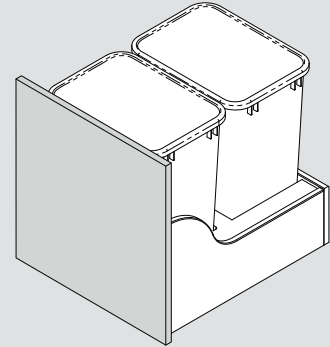

Accommodates a wide range of standard bin sizes. Detailed drawings of recommended drawer box specifications are available at blum.com.

Drawer insertion and removal

Insertion

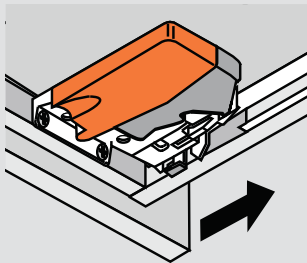

Place drawer on runners and close. Locking devices will automatically connect to runners.

Removal

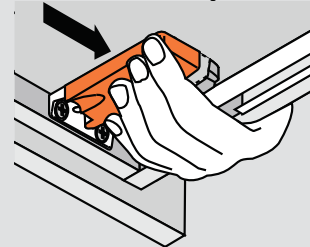

- 1 Squeeze orange handles on locking devices
- 2 Pull drawer straight out and up

Height adjustment

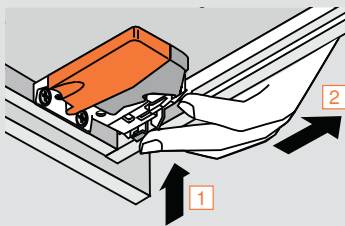

- 1 Press up on adjustment tab
- 2 Push towards back of drawer
Maximum 3 (1/8") rise of drawer front

Tilt adjustment

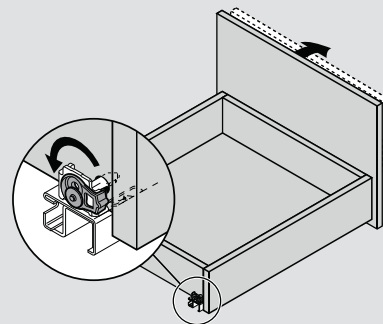

Rotate the tilt adjustment lever on the rear of each runner to tilt top of drawer front forward. Maximum 5 (3/16") rise of drawer back.



Why choose Blum

Blum, Inc. is a leading manufacturer of functional hardware for the kitchen cabinet and commercial casework industries specializing in lift systems, concealed hinges and drawer runner systems. Virtually all of the hardware needed to assemble and make cabinets functional is available within the wide range of quality Blum products. Blum supports the U.S. market with a network of more than 150 dependable distributors, 40+ knowledgeable Blum sales representatives and an experienced customer service department.

Commitment to manufacturing in the U.S.

Blum manufactures many of its products in our 450,000 sq ft manufacturing, logistics and warehouse facility located in Stanley, North Carolina. Manufacturing closer to the customer allows Blum to react quickly to changing customer needs including unexpected surges in demand. Customer pickups and deliveries can be timed to better match their production schedules. Blum is committed to manufacturing in the U.S. for the U.S. market.



Product development at Blum considers all of the various customers who will come in contact with our products. With this "Global Customer Benefits" philosophy we strive to create advantages for all users.



Blum, Inc. is ISO 9001 certified which means that you are assured of consistent quality in every Blum product. What's more they exceed the requirements of ANSI/BHMA standards for cycle life, static load and self-closing performance.



Please visit blum.com for information on other Blum products.
Technical specifications subject to change without notice.
LIT.WRS1000.08.11 © 2011 Blum, inc. Printed in USA

Blum, Inc.
7733 Old Plank Rd.
Stanley, NC 28164
800-438-6788
fax 704-827-0799
blum.com

